

Fingerprint Based Exam Hall Ticket System

Sara Issa Ali Al-Balushi^a, Sumesh E.P.^a

Fingerprint Based Exam Hall ticket Systems are best solutions for universities, colleges and schools. This system is help faculty in reduce the proportion of cheating by entering only authorized persons into exam hall instead of using ID card and help the students in Identify their seats number and knowing the exam module name. Used fingerprint scanner has memory, which can store up to 200 finger print. In addition this system contain database of student information which updated every semester. This system is achieved with the use of fingerprint module, raspberry pi3 and Liquid Crystal Display (LCD) module. When device is switched on to use, student will ask to scan his/her finger, the scanned image will be matched with the stored image to check if its match or not using optical algorithm, the code of fingerprint will be sanded to the SQL database of the raspberry pi.

Keywords: fingerprint; raspberry pi3; MySQL database

Introduction

In this small world the technology improving day after day. Because human thinking is endless every day new ideas implement in the world. It is very necessary to confirm the identity of the student before entering the exam Hall in the schools / universities and colleges. Over a time, the techniques used need to constantly change and differs from one country to another. There are certain standards according to the educational environment and based on the age stages targeted. In Oman, over the years different techniques are used. Previously, the technique used is the student signature only where the student sign in cell which has student name and study code. The technique used is not enough to check the identity of the student. Subsequently been allocated a password number for each student, but all the techniques used are not secure, it is very easy for the unauthorized student to enter the exam hall. In another attempt, has been used a new technique which is using the ID card to identify the student. It helps to reduce the occurrence of any problem in the educational system , It cannot be denied that each technique the pros and cons. Use of ID card takes time to check the identity of the student which cause late for the student and examiner and it's possible to forgery identity or an similarity between students. Think of minimizing any problems with the techniques previously used, is the motive to study new technique, which is fingerprint. By using fingerprint, penetrate the laws become impossible because every person has completely different pattern from the others. The benefit of this system is help the Registration department and proctor in organize the students and exam hall also this system is saving the time of the student and the proctor in checking stage of student identity and know his exam seat number to avoid any messier. This system has the solution for this problem which is use student fingerprint to enter the end semester exams. By this way will be 0% that enters unauthorized student. When device is switched on to use, student will ask to put his/her finger in the scanner, the scanned image will be matched with the stored image to check if its match or not using optical algorithm , the code of fingerprint will be sanded to the SQL database inside raspberry

pi. If the fingerprint is match the data of the student will send to the display screen, if it's not match will show error in the display screen and the process will repeat.

A. Literature Review

There are various methods of scanning the fingerprint and store it as an image, Optical fingerprint scanners is one of the oldest method in comparing and capturing 2D fingerprints images. This technique depends on capturing an optical image and uses an algorithm to analyze the lightest and darkest areas of the image, by detecting unique patterns on finger surface, such as unique marks or ridges. The fingerprint scanning device consisting of a glass plate on top of it to place the finger. After the scanning, an inverted image of the finger is stored (John, 2017).

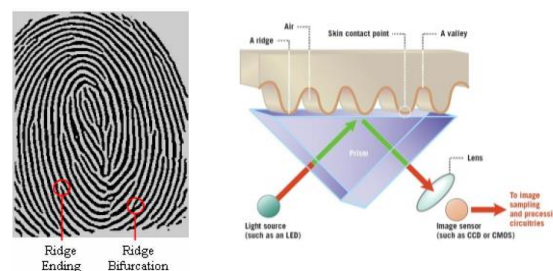

Fig. 1. Type of minutia and Optical scanner

B. Advantages of fingerprints

- It provides a physical evidence for the user.
- It not easily to fake the fingerprints.
- In the case of fingerprint you cannot guess a password of another person.
- There are no possibilities to lose your fingerprint like what happened with the identity card.

a. Department of Electronics and Communication, Middle East College, Muscat, OMAN

As per our survey there exist many projects that use the fingerprint in different fields. Reserved, B.A.R. has design a system which used to authentication (smart card attendance system). The system used in many organizations to cheek if person allowed or not. In this system barcode reader used to read the barcode of ID card, connected to microcontroller circuit. Every person has special card code then other (Reserved,2017). One method of using fingerprint is in security field, Binu has design a system which is locking storage by the fingerprint. is very secure method, can be protect many precious things. In this project the security system has been designed with help 8052 microcontroller, display screen, buzzer & LED (Binu, 2016). There is another method of using fingerprint ,Folorunso, C., L. A. Akinyemi, A. A. Ahasa and Kazeen, has design a system which car starting system. The way of protect the cars from hijackers is using user fingerprint. The aim of this project is to design and develop a fingerprint based car ignition system with a view of reducing car theft and to ward off unauthorized user. The user can add different fingerprint but prompt for passcode first. This system can be done using biometric algorithm. In this system PIC microcontroller circuit has been used with LCD display screen (Folorunso, 2015) .One of the methods used to authentication by fingerprint is fingerprint using raspberry Pi instead of using microcontroller. Raspberry Pi s new technique works as small computer with database, Sapes, J. and Solsona, F. had designed a system which discuss the development of low-cost and competitive security environment of fingerprint recognition and embedded fingerprint with raspberry Pi (Sapes & Solsona,2016).

Design and Implementation

C. block diagram

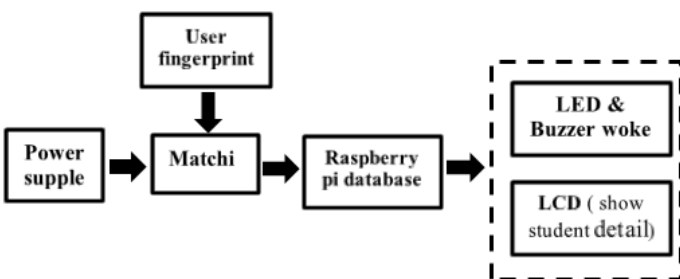

Fig. 2. Block diagram

The block diagram in Fig.2 shows the working of the project. First block is power supply; it gives a dc voltage to the raspberry pi circuit. Second block is fingerprint scanner, it scan the student finger and check if its match or not then its send the finger code to the raspberry pi circuit. Third block is raspberry pi circuit, it will received the code from the finger scanner and check the code from the database and send the information to the output stage. Finally, the LCD displayer will show student detail student name & ID, seat number and exam module name.

D. Flowchart

In registration mode the system allows to register

Fig.3 flowchart

up to 200 users and save it in the system memory. The system will ask to scan the student’s finger three times to store the fingerprint in the database with student’s details. After finishing this process the system will back again to register / store the next student details. The flowchart shows working of the circuit. First step, the fingerprint scanner scan student finger, matching process will work to check if the image matched with the stored image. The code of the fingerprint will be transferred to the raspberry circuit. Second step, if it’s matching, LED and buzzer will work and LCD display will show student details (name, ID, fingerprint, seat number and exam module name). If not match, LED and buzzer will work, and the system will back again to the beginning. The process will repeat again.

E. Hardware and Software requirement

1) Hardware requirement:

a) Fingerprint scanners

This fingerprint is one of the great modules in the market. This module uses on-board optical sensor and CPU of 32-bit. It’s read, identify fingerprints. This module is updated version of the GT-511. Which has an increased capacity memory is increase; it can store up to 200 fingerprints with its database in small memory inside the scanner. This module has four connecting pins: Vcc, GND, Tx, Rx. And the size of it is 37 x 17 x 9.5 mm ((GT-511C3), 2017).

b) LCD

Fig. 3. Fingerprint scanner module

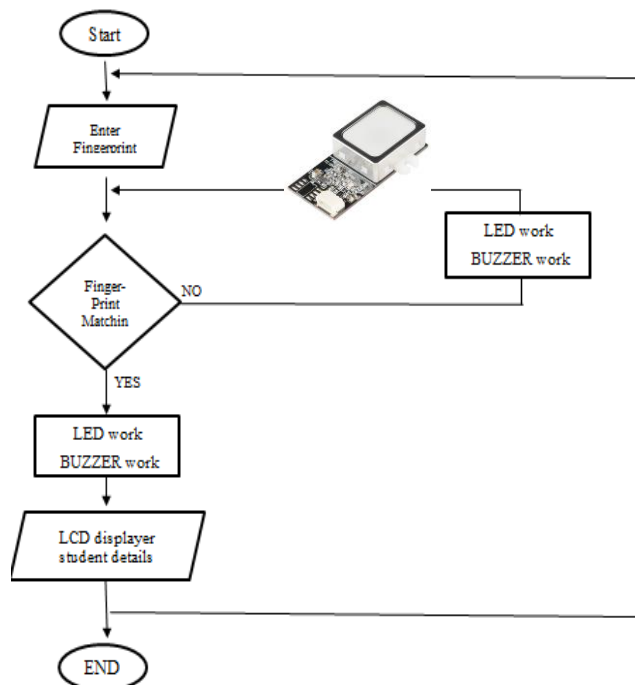

Liquid Crystal Display, have become very important part of day life. There are many things that use LCD like mobile phones, wristwatches, calculators, computers, TV, etc. The use of LCD panels is growing at an incredible fast rate in many applications. LCD is made with either a passive matrix or an active matrix display (a thin film transistor). LCDs displays much thinner than cathode ray tube (CRT) technology (How it works, 2016).



Fig.5 LCD

c) Raspberry pi3

The raspberry pi3 is same as the previous modules but now much faster and with double the ram. The Dimensions is 85mm x 56mm x 17mm (R., 2017).

Major Features of Raspberry pi 3 are listed below:

- Processor SoC running @ 1.2GHz
- 1 GB RAM
- 4 x USB2.0 Ports with up to 1.2A output
- Expanded 40-pin GPIO Header
- Video/Audio Out via 4-pole 3.5mm connector, HDMI, CSI camera, or Raw LCD (DSI)
- Slot to connect micro card



Fig 4 Raspberry pi3

2) Software requirement:

a) Python programming language

Python is a high level programming language which created by Guido Van Rossum. Python used for general purpose programming and it has a design philosophy, in addition to a syntax which allows programmers to express concepts in fewer lines of codes. Also it is available for many operating systems which allow Python code to run on a wide variety of systems En.wikipedia.org. (2017).

b) MySQL database

MySQL is an open-source relational database management system, and the source code of it is available under the terms of the General Public License, also under a variety of proprietary agreements. There are many applications which used MySQL such as: TYPO3, MODx, Joomla, WordPress, phpBB, MyBB, and Drupal. In addition it used in many high-profile, large-scale websites, like Google En.wikipedia.org. (2017).

Acknowledgment

I want to thanks everyone who helped, motivated and supported me from the begging of this project till the end. In the begging I want to thank electronics & communication department for helping me and guide me to complete the project. I would like to thank my supervisor Dr. Sumesh Eratt Parameswaran, and Mr. Ahmed Al-Busaidi who guide me to complete the work.

Result

With the option is enroll new user, new users are added to the memory. memory for fingerprint is starting from 0, all the registered finger prints in this system are from MEC students and total number is 200 fingerprints. The data base created is stored in the SD card, this data base contains user Id, student first and last name and Id card. Second data base is created and is called room database. This data base is populated with the room id of each building, room floor and building. A third table is created called exam database; this table contains the exam information such as module name, module code, module time and date. This data base is designed with five difference modules of MEC course plan. The system is tested for 200 students with their MEC ID and fingerprints and the security is verified by 200 authorized and 50 non authorized students. The prototype has potential to be developed as product with customized PCB design and suitable casing and power supply units. This system is a hand-held system by which the examiner check the student information and if it allow or not to attend the exam also the student can check this exam information.

Conclusion

This project is a prototype operating of a fingerprint based exam hall ticket system. The system is able to communicate well and give appropriate output. The system requests for student's finger process it and check the information from the database and display the output result in the LCD screen. The system also able to enroll new student finger, delete and update the database.

Reference

- John (2010). *Working of fingerprint scanner - electronic circuits and diagram-electronics projects and design*. [Online] Available from: < <http://www.circuitstoday.com/working-of-fingerprint-scanner-2>> [Accessed: 27 December 2016].
- Reserved, B.A.R. ,(2017). *Smart card attendance system*. [Online] Available from: <<http://www.bioenabletech.com/smart-card-attendance-system>> [Accessed: 12 January 2017].
- Binu ,(2007). *Free 8052 Microcontroller based projects*. [Online] Available from: <http://8052projects.blogspot.com/> [Accessed: 21 November 2016].
- Folorunso, C., L. A. Akinyemi, A. A. Ahasa and kazeen, O. (2015) "Design and development of fingerprint based car starting system," International conference and exhibition on power and telecommunications , .

Sapes, J. and Solsona, F. 2016. 'FingerScanner: Embedding a fingerprint scanner in a raspberry pi', 16(2).
(GT-511C3), F., R3, A., Arduino, S., 5V, S., Kit, S., Sensor, M., 5V, F., (GT-511C1R), F., SMD, A., Foot, S. and Yun, A. (2017). Fingerprint Scanner - TTL (GT-511C3) - SEN-11792 - SparkFun Electronics. [online] Sparkfun.com. Available at:

<https://www.sparkfun.com/products/11792> [Accessed 7 May 2017].

How-it-works: Flat-panel LCD display technology, 2002. [Online] Available from: <<http://www.practical-home-theater-guide.com/lcd-display.html>> [Accessed: 16 November 2016].

R., IBM TjBot, a., Kit, R., Module, S., PiRetrocade, S., 10), m., Touch, S., (Green), P., Cable, U., C, B. and V2, R. (2017). *Raspberry Pi 3 - DEV-13825 - SparkFun Electronics*. [online] Sparkfun.com. Available at: <https://www.sparkfun.com/products/13825> [Accessed 7 May 2017].

En.wikipedia.org. (2017). *Python (programming language)*. [online] Available at: [https://en.wikipedia.org/wiki/Python_\(programming_language\)](https://en.wikipedia.org/wiki/Python_(programming_language)) [Accessed 7 May 2017].

En.wikipedia.org. (2017). *MySQL*. [online] Available at: <https://en.wikipedia.org/wiki/MySQL> [Accessed 7 May 2017]