

Design of a Physical Therapy Device for Lower Leg Recovery

Ashna Khemani¹ and Katie Hahm^{2#}

¹American High School

²Massachusetts Institute of Technology

#Advisor

ABSTRACT

Currently, some physical therapy requires another person to assist in exercises that rehabilitate patients with leg injuries such as sprains and fractures. In this paper, we propose a device that can help strengthen muscles that have weakened due to injury without the help of another person. The device is portable and can be used in a home setting, and the amount of resistance it provides can be adjusted by the patient. We suggest a design that aids patients in lower leg rehabilitation and can adjust for the patient's preference in exercise type and intensity.

Introduction

Injuries of the lower limb take a toll on patients. One half of all generic injuries result in restricted activity. Of this, three-fourths are lower body sprains and fractures, which also constitute 40% of bed disability cases (Collins, 1990). Put together, lower limb fractures and sprains affect over 15 million Americans every year (Collins, 1990).

Stroke patients are also susceptible to losing full function of their lower limbs. Though neural issues are a factor in hemiparesis, the inactivity and resulting atrophy can also contribute. However, patients with some motor control were able to regain more strength and functionality through resistance exercises (Dobkin, 2005).

Additionally, patients who undergo hallux valgus surgery are often unable to regain proper gait. However, patients who follow a postoperative physical rehabilitation regimen are able to increase the strength of the operated foot, leading to a more correct gait. Such physical therapy effectively helps patients regain proper function after surgical treatments for musculoskeletal disorders (Schuh et al., 2009).

Patients typically get help from a professional physical therapist to understand their current weaknesses and how they should exercise to increase their strength in those areas. However, the physical therapist won't sit everyday with the patient when they must do their exercises -- they simply show the patient how the exercises must be done, and then it is the patient's responsibility until the next visit to regularly do the exercises.

This is where physical therapy often gets challenging. Some of the exercises, such as plantarflexion, dorsiflexion, inversion, and eversion require the use of a resistance band (Dobkin, 2005). Holding the band in place is necessary to provide the resistance that is required for effective strength building. This may be challenging for some patients, especially those who may be infirm or have upper body injuries as well, as they may not have the strength to hold the band in place.

In this paper, we propose a design for a device that allows a patient to complete his or her physical therapy exercises independently. We first discuss similar works and their shortcomings. We then specify functional and design requirements for an improved mechanism, then propose a design that fits these criteria. We are also able to calculate the forces that would be in play and specify what parts may be used to build such a design. We then suggest possible improvements and additions that can be made to make this a more effective device.

Related Works

There are several products available for leg injury patients to use. One such example is an exoskeleton that is worn on the lower body and helps the patient follow the motions of walking (Stopforth, 2017). However, these exoskeletons require assistance and supervision from a professional, and are largely meant for clinical use. Furthermore, they are also too costly for patients to buy themselves and are not portable. There is also a virtual reality cycling system that helps patients build equal strength and proper balance in their legs (Yin et al., 2016). However, this is not a portable system and it also requires connection to a display and setup in order to work effectively. Another currently popular solution is an anti-gravity treadmill that supports the patient's body weight as part of the process of slowly building strength in the legs and a proper gait (Tenforde et al., 2012; Cernak et al., 2008). However, like the exoskeleton, it too is meant for clinical use, is costly, and not portable.

Design

Some of the popular exercises for leg recovery involve the use of a resistance band, where the patient attempts to move their foot in a particular direction while using the band to create a resisting force. Our device's purpose is to hold the resistance band in place so that the patient can feel the full magnitude of this resisting force, and thus exercise their leg effectively without the assistance of another person.

Requirements

Throughout the rehabilitation process, patients must regularly exercise their legs. The recommended exercises typically involve increasing lower leg strength by moving the ankle in different directions. The most basic such movements are plantarflexion, dorsiflexion, inversion, and eversion, as illustrated in Fig. 1 (Vloka & Hadzic).

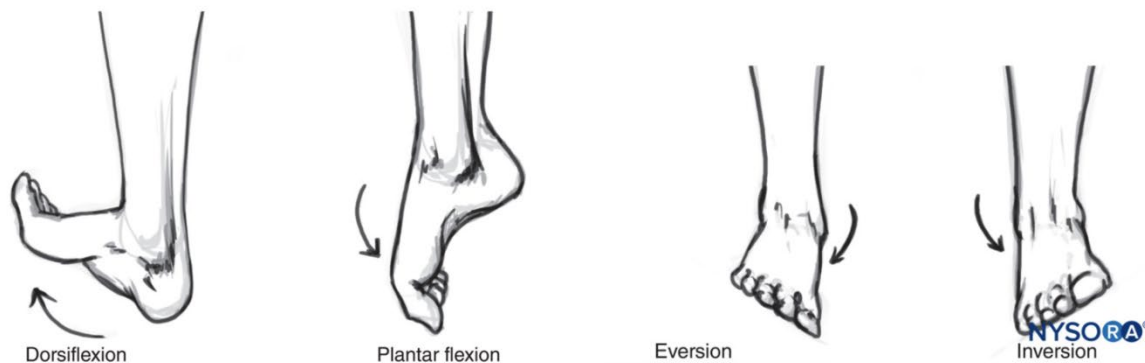

Figure 1. Diagram of four major types of foot movement: plantarflexion, dorsiflexion, inversion, and eversion (Vloka & Hadzic).

To allow for all four of these types of movement, we specified requirements for the device as, Functional Requirements:

- Device must be able to push against foot in multiple directions and magnitudes
- Device should not move around while patient is using it
- Patient can easily adjust device for changes in exercise type and intensity
- Device should be portable
- Device should be easy to use, such that a patient can operate it on their own without assistance

Design Requirements:

- Device must be able to provide a sufficient resistance force in multiple directions and magnitudes
- Device must be able to withstand up to 512 N of force
- Device should be small and light so it may be easily carried

Adjustable Resistance Mechanism

There are different ankle exercises that aim to strengthen better movement in different directions. The exercises this machine aims to help with are plantarflexion, dorsiflexion, inversion, and eversion (Fig. 1). As noted in the requirements, the machine should be able to provide resistance in different directions in order to aid with these exercises and should also be able to adjust the magnitude of the resisting force. The user may gauge whether the current resisting force is too little or too much and can adjust it accordingly using some control, such as a remote. The different exercise types can be achieved by holding the resistance band in different positions and angles, which can be done by simply moving the endpoints of the band. Possible configurations for the four main exercises are shown below in Fig. 2 (Border Podiatry Centre, 2018).

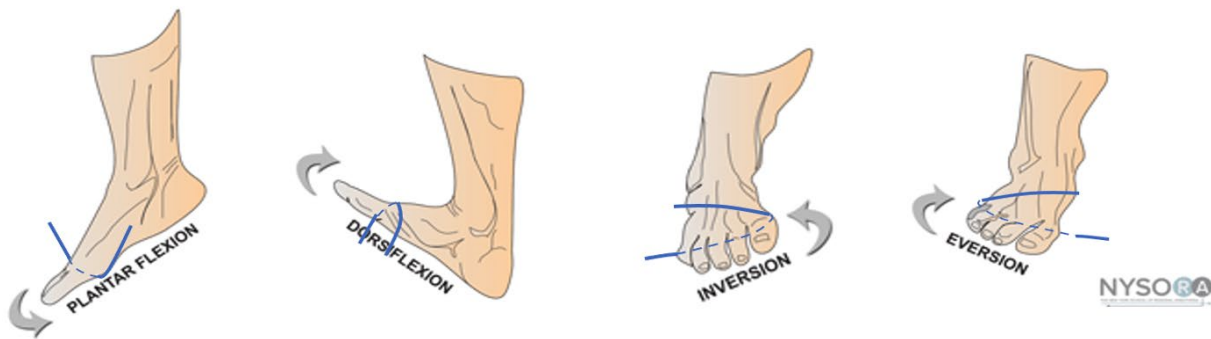

Figure 2. Exercise band configurations that provide appropriate resistance force for each type of movement (Border Podiatry Centre, 2018).

Lead Screw Linear Actuation

Lead screw assemblies were used as a way to achieve the design for the adjustable resistance mechanism, as they can reliably move the band’s endpoints (mounted on the lead nuts) and support the large forces from the patient’s foot.

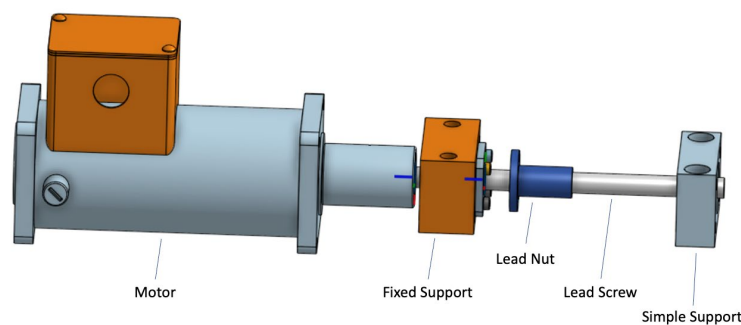

Figure 3. CAD model of a lead screw assembly. The final design uses two such assemblies. Each end point of the exercise band is mounted to the lead nut, which travels along the lead screw as the motor turns.

Though they are not necessarily fast linear actuators, lead screw assemblies have the necessary torque to overcome large external forces because they are non-back drivable. The high force and torque are needed to overcome the strength of the patient's foot, which, depending on how much the patient has recovered, is enough to carry the patient's weight while walking. The non-back drivability of lead screw systems means the band will not move with the motion of the patient's foot and will instead stay in place as the patient moves their foot as part of the exercise. This means that the motor will not need to continuously run to oppose force from the patient's foot, thus saving battery power. A lead screw system also permits adjustable resistance levels as the lead nuts can move to easily stretch the band over the patient's foot. In this design, two lead screw assemblies, each supporting one of the band's endpoints, are mounted on a base with an indent to support the patient's foot (Fig 4).

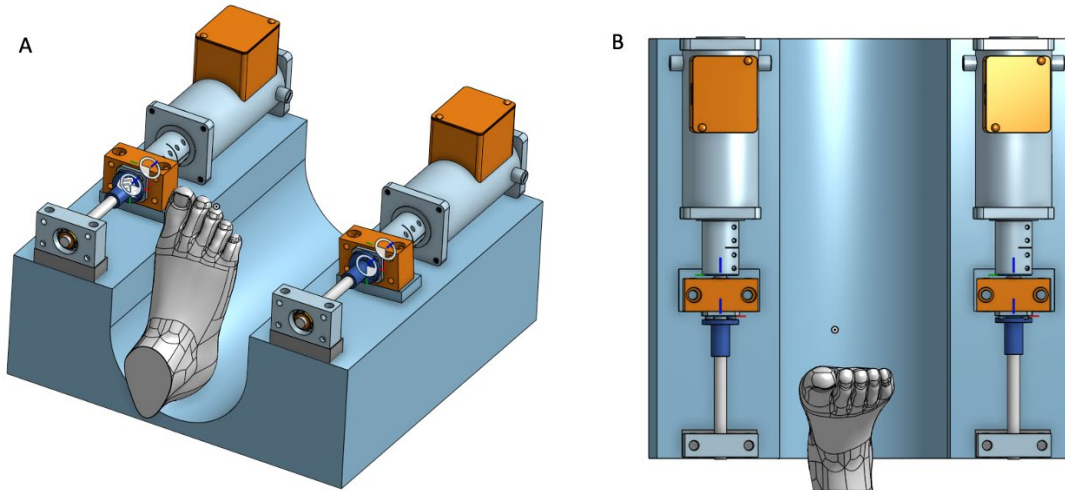

Figure 4. CAD model of the full assembly; two lead screw assemblies mounted on a base with an indent for the patient's foot. a) side view b) top-down view

The different band configurations for each of the different exercises can be achieved by moving the lead nuts, which hold the band's endpoints, to different positions relative to the patient's foot. The four possible configurations, each for a different exercise, are shown below in Fig. 5.

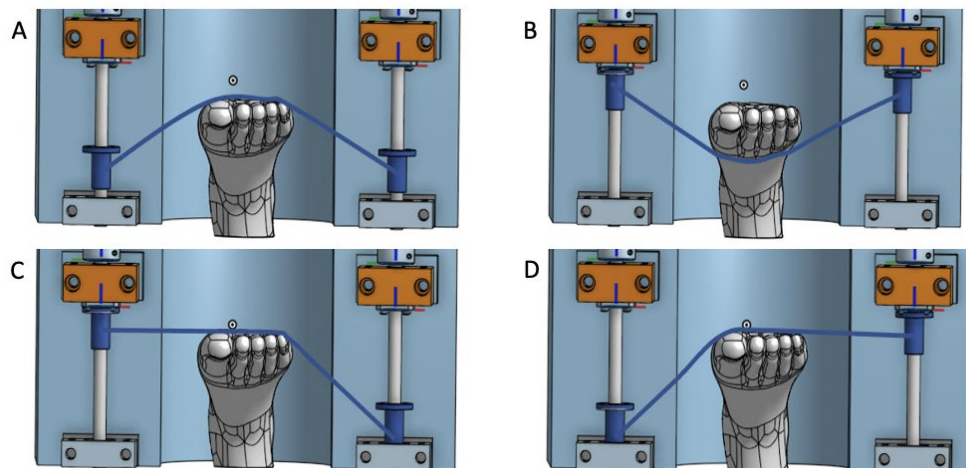

Figure 5. Using two lead screw assemblies to allow for appropriate resistance vectors for a) plantarflexion, b) dorsiflexion, c) eversion, and d) inversion.

The magnitude of resistance can also be adjusted by further adjusting the endpoints of the resistance band. Because of its elastic properties, the resistance force provided by a resistance band is directly proportional to the distance it is stretched (ProHealthcareProducts, 2009). Thus, moving the endpoints along the axes in such a way that the band stretches differently over the patient's foot can change the amount of resistance provided by the machine. Fig. 6 shows such adjustments for each of the exercises that result in a weaker resistance force.

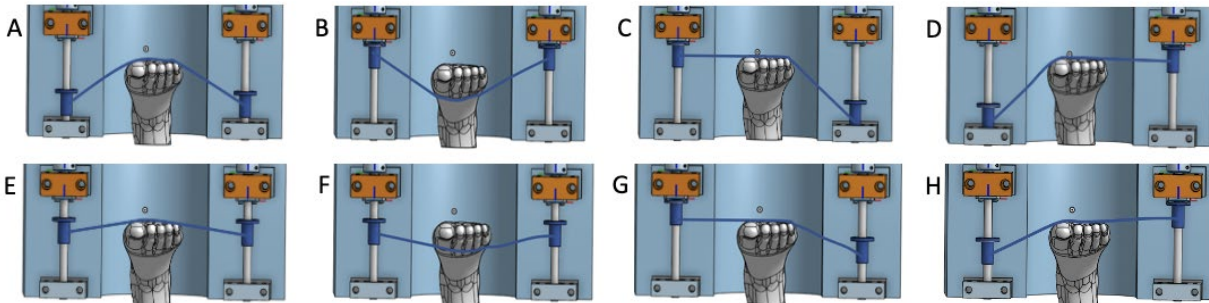

Figure 6. Adjusting lead nut positions to change magnitude of resistance forces. Images A-D are seen in Fig. 5. Images E-H are the same exercises in A-D but with less resistance (due to the slightly different lead nut locations).

Support for Base

Because of the strong forces in play, it is possible for the entire base to slide or move along with the patient's foot. A solution to hold it in place is having a base be attached to a tray that goes under the patient's lower body/upper legs. The weight of the patient would be enough to hold the entire machine in place. To allow for portability, the tray will be foldable/collapsible, and can be stored underneath the base.

Analysis

To determine whether typical hardware could be used for this machine, we computed the force that might be exerted on the machine and found the range of forces that the machine can supply.

Biomechanical Force Analysis

In order to determine an optimal lead screw configuration, the forces exerted on the machine had to be found. The maximum torque exerted by the ankle is approximately 45.2 Nm, and the mean foot length is about 258.1 mm (de Leva, 1996; Simpson et al., 2018). The force exerted through ankle dorsiflexion can be calculated:

$$Force = \frac{Torque}{Radius}$$

where radius can be considered as foot length. Therefore:

$$Force = \frac{45.2 Nm}{258.1 mm} = 175.13 N$$

Next, we calculated the force exerted through plantarflexion of the ankle. The maximum mean torque found for ankle plantarflexion is 132.1 Nm (Morau et al., 2013). Using the same foot length and methods for dorsiflexion:

$$Force = \frac{Torque}{Radius} = \frac{132.1Nm}{258.1mm} = 511.8N$$

For inversion and inversion, it is safe to assume the force exerted by these movements is less, as the range of motion along these axes is far less (Brockett & Chapman, 2016). Thus, the maximum force that might be exerted on the device is 511.8 N from plantarflexion of the ankle.

Actuator Specification Calculations

As noted in the Design section, a lead screw assembly is used in our design. In general, the torque needed to run a lead screw is:

$$\tau = \frac{Fd_m}{2} \left(\frac{l + \mu\pi d_m}{\pi d_m - \mu l} \right)$$

where:

- τ is the torque the lead screw must turn at in order to support the load. In order to match the units for the formula above, this is measured in $lb \cdot in$.
- F is the load on the lead screw assembly. As calculated from the biomechanical force analysis, this will be 511.8N. We converted this to 115.1lbs in order to match the units for the formula above.
- d_m is the pitch diameter of the lead screw. The screw we used in our design has a pitch diameter of 0.5 in.
- l is the distance between threads on the lead screw. The screw we used in our design has 10 threads per inch, which means the distance between each thread must be 0.1 in.
- μ is the coefficient of friction. As we are using steel-on-steel for our proposed design, this is approximately 0.1

(Shigley et al., 2004).

Substituting in the values into the lead screw torque formula above, we get:

$$\tau = \frac{115.1lbs \times 0.5in}{2} \left(\frac{0.1in + 0.1 \times \pi \times 0.5in}{\pi(0.5in) - 0.1(0.1in)} \right) \approx 4.7lb \cdot in \approx 0.5Nm$$

Thus, for this design to be physically built, a motor with a torque of at least 0.5Nm should be used to support a force of 512N as calculated in the biomechanical force analysis.

Range of Possible Forces

Next, we calculated the range of forces the device, paired with a resistance band, is able to provide. For our calculations, we assume the resistance band is a “green” level Theraband starting at 25 percent elongation at 11.3in long. This provides 2lbs of resistance (ProHealthcareProducts, 2009). The maximum distance the lead nuts carrying the band’s endpoints can traverse along the lead screw is 5.5in.

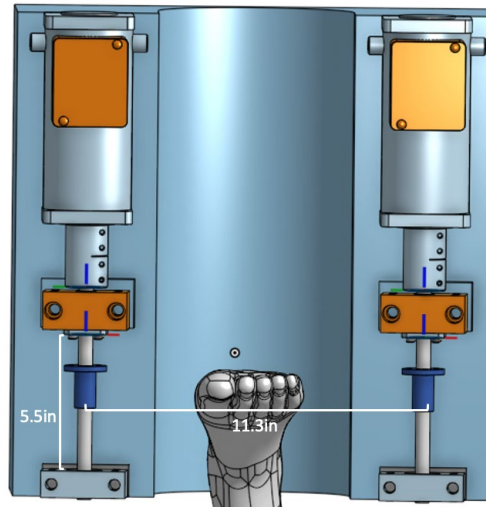

Figure 7. Dimensions of the lead screw assembly. The resistance band starts stretched at 11.3in. Each endpoint on a lead screw can travel along a 5.5in path.

The longest possible elongation of the band can be calculated as follows:

1. At maximum elongation, the push from the plantarflexion of the ankle and resulting bend in the band form an isosceles triangle; the two congruent sides are the two halves of the band, and the base is the constant distance between the lead screws, 11.3in
2. Let x be the length of one half of the band; the distance from a lead nut to the halfway point, or bend, in the band
3. Let h be the height of the isosceles triangle; the distance from the bend in the band to the halfway point of the triangle's base. This is essentially the length of the lead screw's path, 5.5in
4. We now have a right triangle, with vertical height $h = 5.5in$, horizontal base length $b = \frac{11.3in}{2} = 5.65in$, and hypotenuse x
5. Using Pythagoras' Theorem, we can find x :

$$x = \sqrt{h^2 + b^2} = \sqrt{5.5in^2 + 5.65in^2} \approx 7.9in$$

6. x is half the length of the band. To find the total length of the band l we simply multiply x by 2:

$$l = 2x = 2 \times 7.9in \approx 15.8in$$

Thus, the maximum elongation length of the resistance band on this device is about 15.8in. To find the force this exerts, we first must find the percent elongation:

1. First, we find the length of the band at 0 percent elongation. We know the band is at 11.3in at 25 percent elongation, so:

$$l_{25\%} = 1.25l_{0\%}$$

$$l_{0\%} = \frac{l_{25\%}}{1.25} = \frac{11.3in}{1.25} = 9.04in$$

2. Now we can find the percent elongation of the maximum length $l_{max} = 15.8in$:

$$\text{Percent elongation} = \frac{l_{max}}{l_{0\%}} = \frac{15.8in}{9.04in} \approx 1.75 = 175\%$$

The maximum 175 percent elongation for a “green” level band exerts a force of 7.2lbs (ProHealthcareProducts, 2009). At the beginning of this subsection, we identified that the band on the device starting at 25% elongation has a force of 2lbs.

Thus, the device can provide resistance forces for the ankle exercises in the following range:

$$2lbs \leq Force \leq 7.2lbs$$

or

$$8.9N \leq Force \leq 32N$$

Conclusion and Future Work

We developed a device that can aid in practicing physical therapy without the need for another person’s assistance. It provides four modes of movement and is portable. Possible improvements of this design involve implementing sensors to automatically adjust the magnitude of resistance depending on how much the patient’s foot pushes the band. There may also be a more personalized user interface and feedback mechanism. The machine may track and communicate how the patient’s strength builds over time, and whether they are doing the exercises properly.

Acknowledgements

I would like to thank my mentor Katie Hahm for guiding me throughout this project and her invaluable feedback during the writing process.

References

- Border Podiatry Centre. (2018). The "Lateral" Ankle Sprain. <https://www.borderpodiatrycentre.com.au/the-lateral-ankle-sprain/>.
- Brockett, C. L., & Chapman, G. J. (2016). Biomechanics of the ankle. *Orthopaedics and trauma*, 30(3), 232–238. <https://doi.org/10.1016/j.mporth.2016.04.015>
- Cernak, K., Stevens, V., Price, R., & Shumway-Cook, A. (2008). Locomotor Training Using Body-Weight Support on a Treadmill in Conjunction with Ongoing Physical Therapy in a Child with Severe Cerebellar Ataxia. *Physical Therapy*, 88(1), 88–97. <https://doi.org/10.2522/ptj.20070134>
- Collins, JG. (1990). Types of injuries by selected characteristics: United States, 1985-87. National Center for Health Statistics. *Vital Health State* 10(175).
- de Leva, P. (1996). Adjustments to Zatsiorsky-Seluyanov's Segment Inertia Parameters. *Journal of Biomechanics*, 29(9), 1223–1230. [https://doi.org/10.1016/0021-9290\(95\)00178-6](https://doi.org/10.1016/0021-9290(95)00178-6)
- Dobkin, B. H. (2005). Rehabilitation after stroke. *New England Journal of Medicine*, 352(16), 1677–1684. <https://doi.org/10.1056/nejmcp043511>

Morau, A., Canal, A., Ollivier, G., Ledoux, I., Doppler, V., Payan, C., & Hogrel, J.-Y. (2013). Ankle Dorsi- and Plantar-Flexion Torques Measured by Dynamometry in Healthy Subjects From 5 to 80 Years. *BMC Musculoskeletal Disorders*, 14(1). <https://doi.org/10.1186/1471-2474-14-104>

ProHealthcareProducts. (2009, October 22). *Thera-Band Colors Sequence Resistance Levels*. [prohealthcareproducts.com](https://www.prohealthcareproducts.com/blog/theraband-colors-sequence-resistance-levels/). <https://www.prohealthcareproducts.com/blog/theraband-colors-sequence-resistance-levels/>.

Schuh, R., Hofstaetter, S. G., Adams, S. B., Pichler, F., Kristen, K.-H., & Trnka, H.-J. (2009). Rehabilitation after hallux valgus surgery: Importance of physical therapy to restore weight bearing of the first ray during the stance phase. *Physical Therapy*, 89(9), 934–945. <https://doi.org/10.2522/ptj.20080375>

Shigley, J. E., Budynas, R. G., & Mischke, C. R. (2004). *Mechanical Engineering Design*. Mc Graw-Hill.

Simpson, D., Ehrensberger, M., Nulty, C., Regan, J., Broderick, P., Blake, C., & Monaghan, K. (2018). Peak Torque, Rate of Torque Development and Average Torque of Isometric Ankle and Elbow Contractions Show Excellent Test–Retest Reliability. *Hong Kong Physiotherapy Journal*, 39(01), 67–76. <https://doi.org/10.1142/s1013702519500069>

Stopforth, R. (2017). Customizable Rehabilitation Lower Limb Exoskeleton System. *International Journal of Advanced Robotic Systems*, 9(4), 152. <https://doi.org/10.5772/53087>

Tenforde, A. S., Watanabe, L. M., Moreno, T. J., & Fredericson, M. (2012). Use of AN ANTIGRAVITY treadmill for rehabilitation of a Pelvic stress injury. *PM&R*, 4(8), 629–631. <https://doi.org/10.1016/j.pmrj.2012.02.003>

Vloka, J. D., & Hadzic, A. (n.d.). *Motor responses obtained on stimulation of the sciatic nerve in the popliteal fossa*. Popliteal Sciatic Nerve Block – Landmarks and Nerve Stimulator Technique. NYSORA. <https://www.nysora.com/regional-anesthesia-for-specific-surgical-procedures/lower-extremity-regional-anesthesia-for-specific-surgical-procedures/foot-and-ankle/block-sciatic-nerve-popliteal-fossa/>.

Yin, C., Hsueh, Y.-H., Yeh, C.-Y., Lo, H.-C., & Lan, Y.-T. (2016). A Virtual Reality-Cycling Training System For Lower Limb Balance Improvement. *BioMed Research International*, 2016, 1–10. <https://doi.org/10.1155/2016/9276508>