

An Analysis and Survey on the Aerodynamics of F1 Car Design

Arnav Pandit¹ and Gwyn Harold George Day¹

¹The Shri Ram School Aravali, Gurugram, Haryana, India
DOI: <https://doi.org/10.47611/jsrhs.v10i2.1475>



ABSTRACT

Formula One (also known as F1) is the highest class of [single-seater](#) open-wheel and open-cockpit professional motor racing contest. Formula One racing is governed and sanctioned by a world body called the FIA – Fédération Internationale de l'Automobile or the International Automobile Federation^[1]. There is not much room to differentiate in the design of the engine and wheels of F1 cars. As there is not much scope for innovation in these aspects of an F1 car, most innovation is left to the aerodynamic design of the F1 car. The aerodynamics team considers many different principles when designing the car. In this paper, we will be first examining these aerodynamic principles and then discussing how they are applied to F1 cars. A survey has also been conducted among over 200 professionals/academics involved in STEM to get an idea of people's opinions on F1 Car Aerodynamics. The data collected, through a survey on Amazon Mechanical Turk, has been analyzed to see if it agrees with the reality. The hypothesis that while people have knowledge of general STEM, their F1 Aerodynamics knowledge, while logically sound, often fails to recognize certain intricacies of the sport, has been proven by the collected data. While there are many papers have already been written on F1 Aerodynamics, this is the first to provide one in relation to the specific parts. It is also the first to conduct a survey among people and provide analysis for the same.

How are F1 and Aerodynamics Related

In the world of F1, the aerodynamicist is king, the man (or woman) who can figure out how to generate large downforce with less drag is worth more to their teams than the driver, who is the face of the team.

F1 cars operate at speeds far beyond that of a regular car due to which, several aerodynamic precautions must be taken to ensure that the car does not become airborne due to lift generation, which is associated with high wind velocity.

Aerodynamics is also necessary to ensure that the car moves the fastest it possibly can despite large amounts of high-speed wind flowing in the opposite direction, which it has to pass through. It ensures that the driver gets maximum possible control of his car.

Some Basic Aerodynamic Principles Applied in F1 Cars

Have you ever wondered why plane wings are shaped the way they are, or why sports cars have those tails at the back? Or why golf balls have so many dimples on them? Well, all these questions are answered by aerodynamics. To understand aerodynamics, I suppose we have to start somewhere. Let us start with the most fundamental concept of all concepts of physics, forces.

The design of a typical F1 car is in accordance with many aerodynamic principles. Such as

- The Aerodynamic Forces- Drag, Thrust, Lift, and downforce
- Airfoil shape and the laws behind this design
- Angle of attack of an airfoil
- Turbulent Laminar and Transient Flow
- Vortices
- Center of Pressure
- Venturi effect

The Aerodynamic forces

In any system, the most important thing to understand, are the forces present in the system. In any fluid, there are 4 forces, called the aerodynamic forces. The aerodynamic forces or forces of flight are the forces which act on all bodies moving through a fluid. They are

- Lift
- Weight (downforce in F1 car)
- Thrust
- Drag

Fig 1. The 4 aerodynamic forces

Thrust and Drag

Thrust is the force that moves the body through the fluid. It is exerted in the direction of the force. The greater the thrust of a body, the more its velocity.

Drag is the force that opposes the motion of the body in a fluid. It can be considered as the friction of aerodynamics. Its direction is the opposite to that of thrust.

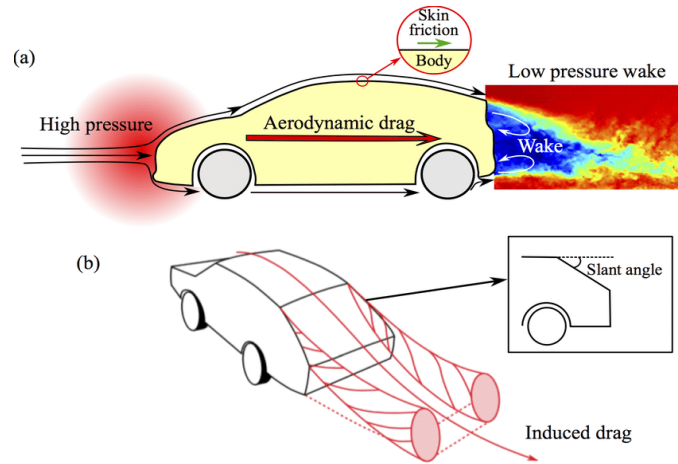

Fig 2. The 2 types of drags

Drag is produced in a body in two ways-

- Friction between the layers of the fluid and the surface in contact with fluid, due to viscosity of the fluid. A more viscous fluid like honey will produce more drag than a less viscous fluid like water. This is called aerodynamic drag.
- Pressure difference between the two ends of the body, as force acts from an area of high pressure to an area of low pressure, this is called induced drag.

Lift and Weight (downforce)

Lift is the force that acts on a body moving in a fluid opposite to the force of its weight (gravity). In planes, the lift

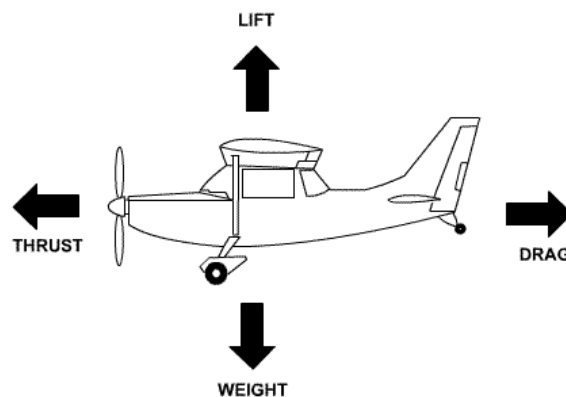

force is responsible for flight and plane wings are designed to produce the maximum amount of lift with least drag^[2]. However, in F1 cars, lift is an undesirable force as it reduces the traction of the tires and of course, you do not want a

flying car. Weight is the effect of earth gravitational pull on the body. In planes, lift force is generated to overcome the weight.

F1 cars produce a special force called downforce, which is in the same direction as weight, the various parts of an f1 car such as front wing, rear wing and ground plates are designed to produce the maximum possible downforce. Downforce is critical to F1 cars it produces traction, giving the driver better grip and it increases velocity However, downforce comes at a heavy price, a high amount of downforce results in a high amount of drag. Aerodynamicists are constantly trying to find ways to produce downforce without drag.

Now we know all about the forces, but how are they generated? That brings us to the airfoil shape and Bernoulli's Principle.

Airfoil Shape

The airfoil shape is the basis of all aerodynamic objects. It is derived from the teardrop, the most aerodynamically efficient shape. The airfoil is rounded on one surface and flat on the other. The most widely accepted explanation of the airfoil shape is the Bernoulli's principle. The Bernoulli's principle is the law of conservation of energy applied to fluids. "As the velocity of a moving fluid (liquid or gas) increases, the pressure within the fluid decreases."^[3]

In an airfoil, due to the irregular shape, the fluid moving over upper surface has a longer distance to travel as compared to the fluid moving over the lower surface due to which its velocity increases. As the fluid moving over the upper surface has a high velocity it has a lower pressure compared to the lower surface. Due to this pressure gradient, lift is produced. This logic using Bernoulli's principle in distance is known as the Equal Transit Theory.

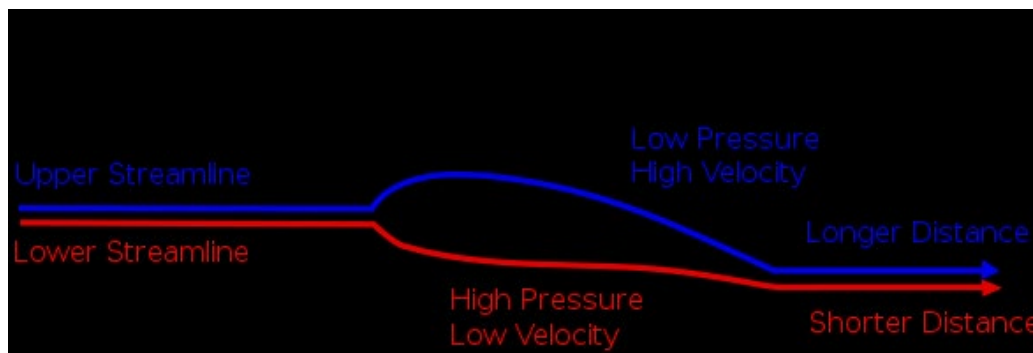

Fig 3. The Equal Transit Theory in action

Angle of Attack

It is the [angle](#) between a [reference line](#) on a body (often the [chord line](#) of an [airfoil](#)) and the [vector](#) representing the relative motion between the body and the fluid through which it is moving.^[4] In simpler terms it is the angle between the line of the chord of an airfoil and the relative airflow. A chord is the imaginary straight line joining the leading edge and trailing edge of an airfoil.

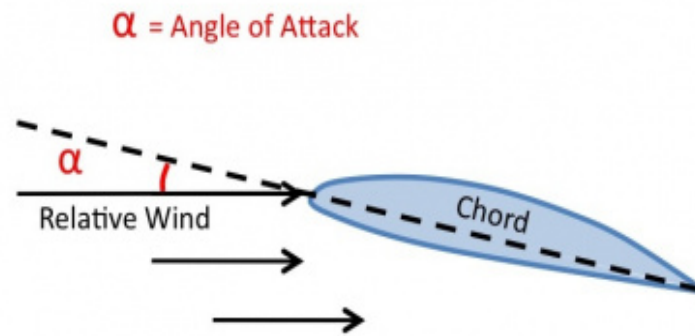

Fig 4. Diagrammatic Representation of Angle of Attack

The angle of attack determines the amount of lift generated by an airfoil, the more the magnitude of the angle of attack the more the lift generated. As the angle of attack decreases and becomes negative, the downforce starts increasing, meaning there is a negative lift produced. This is called downforce. A negative angle of attack generates downforce. This is what is applied in F1 cars.

Determining the angle of attack

In theory, it would seem obvious to keep the angle of attack as high as possible; however, this is not true in practice as it leads to something called boundary layer separation (explained later).

Therefore, having a very large angle of attack is disadvantageous, as the location of the separation point moves closer and closer to the front part of the airfoil. However, it cannot be too low either, as that will not produce much force as the air pressure gradient will not be enough.

In the last case, the turbulent wake is a region of low pressure, thus there is a pressure gradient. There is low pressure behind the airfoil (due to turbulent air) and high pressure in front (where there is laminar (uniform) air flow) therefore the low pressure of the turbulent air exerts an opposing force on the airfoil, this is induced drag, which is why the angle of attack cannot be too high.^[5]

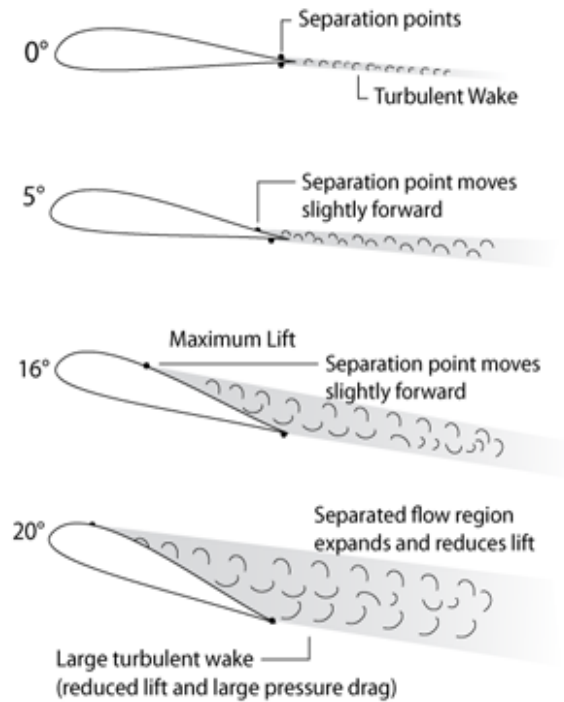

Fig 5. Various Angles of Attacks

Critical Angle of Attack

It is the maximum possible angle of attack for a given airfoil and fluid where induced drag(stalls) does not occur, is the critical angle of attack. For most cases, the critical angle of attack is between 15 to 18 degrees.

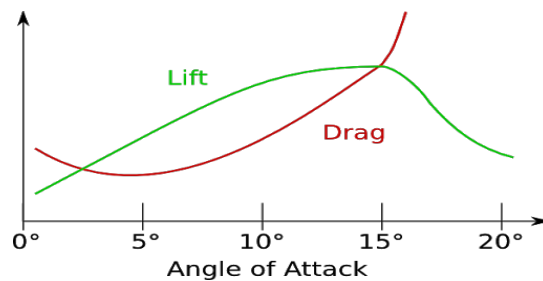

Fig 6. Angle of Attack Vs Lift

Turbulent, Laminar and Transient Flow

Turbulent flow is a type of fluid flow in which the fluid undergoes irregular fluctuations characterized by eddies and currents. In turbulent flow the speed of the fluid at a point is continuously undergoing changes in both magnitude and direction.

Transient flow is the flow in which the fluid is transitioning from turbulent to laminar flow or vice versa.

Laminar flow occurs when the fluid flows in infinitesimal parallel layers with no disruption between them. In laminar flows, fluid layers slide in parallel, with no eddies, swirls or currents normal to the flow itself. The speed of the fluid at any point has constant magnitude and direction.

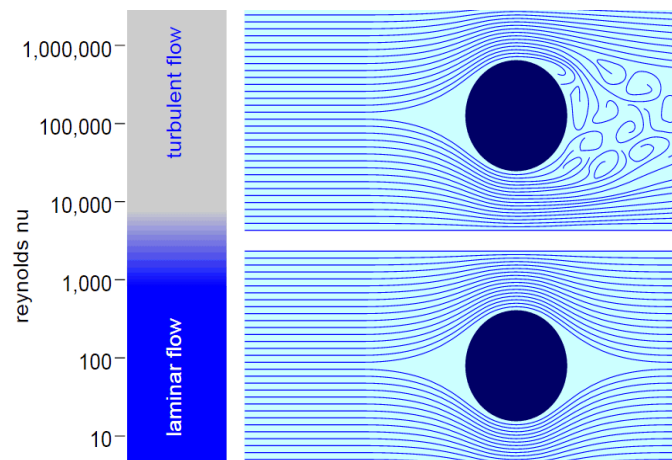

Fig 7. Reynold's Number of fluid flows

Reynolds Number

The Reynolds number (Re) is a [dimensionless](#) in [fluid mechanics](#) used to help predict flow patterns in different fluid flow situations. At low Reynolds numbers, flows tend to be dominated by laminar (sheet-like) flow, while at high Reynolds numbers turbulence results from differences in the fluid's speed and direction. It is named after British physicist Osborne Reynold.

Vortices

In [fluid dynamics](#), a vortex is a region in a fluid in which the flow revolves around an axis line, in simple terms a vortex is rotating fluid. The fluid pressure in a vortex is lowest in the center and rises progressively with distance from the center. This is in accordance with Bernoulli's Principle. In the world of F1, vortices have a positive as well as negative effect

Positive Effect:

Vortices are used to prevent boundary layer separation at high angles of attack, as they are regions of low pressure, they pull the separated layer towards the airfoil. The front wing produces the beneficial vortices in an F1 car. They also act as a barrier between the turbulent air produced by the tires and the rest the body of the car. Particularly the bottom where the ground effect takes place (more on that later).

Negative Effect:

Vortices however, are disadvantageous when generated at the back of the car, as vortices are low pressure regions, a pressure gradient is established between the back of the car (low pressure) and the front of the car (high pressure).



Due to this drag is generated, this kind of drag is called induced drag. Such vortices are produced by the rear wing and are called wing tip vortices. These are also produced in air planes, also called wake vortices. Wing tip vortices are prevented by constructing specially designed endplates or winglets.^[6]

Fig 8. Wake Vortices

Vortex generation

Vortices form on a wing which has a pressure gradient established across its surfaces. vortices form because of the difference in pressure between the upper and lower surfaces of a wing that is operating at a positive or negative lift. The tendency is for particles of air to move from the lower pressure surface around the wing tip to the surface of higher pressure (from the region of high pressure to the region of low pressure) so that the pressure becomes equal above and below the wing. When the air leaves the trailing edge of the wing, the air from the upper surface is inclined to that from the lower surface forming vortices.

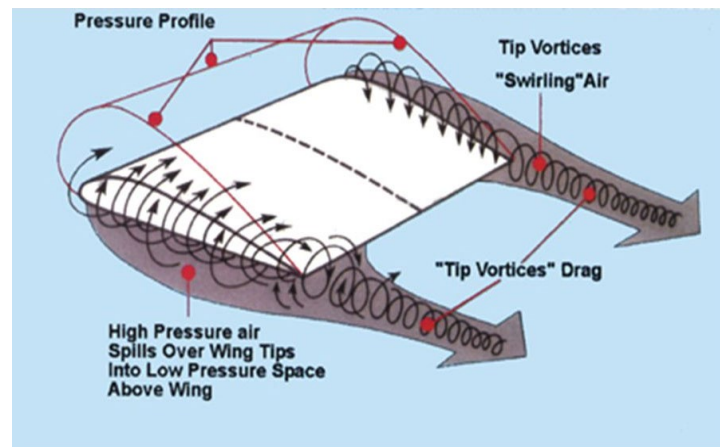

Fig 9. Typical Generation of a Vortex

Center of Pressure

In fluid mechanics, the center of pressure is a point where the total pressure field can be considered to act on a body. In a body the force generated due to a pressure gradient can be considered to act along the center of pressure. The center of pressure is to aerodynamic what center of gravity is to classical mechanics. Just like how all weight of a body can be considered to act at the center of gravity, all pressure of a body can be considered to act at the center of pressure.^[7]

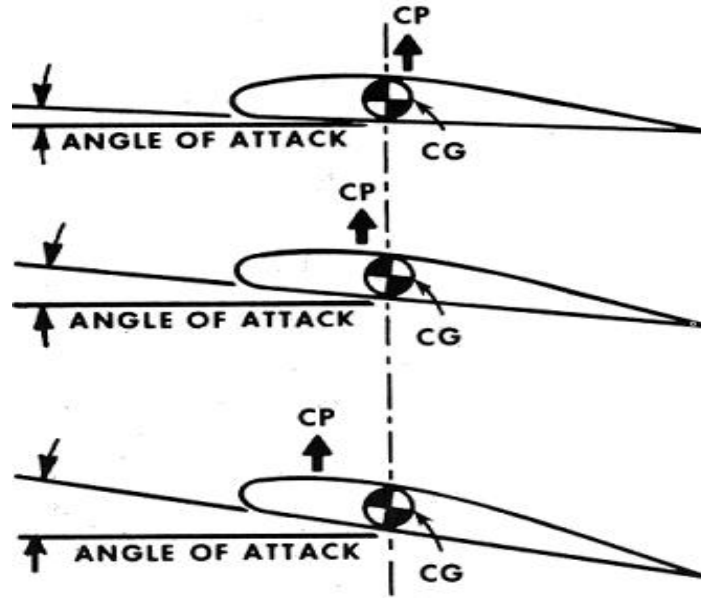

Fig 10. Variation of center of pressure with angle of attack

The relative position of the Center of Pressure and Center of Gravity determines the stability of the body if the Center of Pressure is behind or in front of the center of Gravity, the body will not be stable. If the Center of Pressure and Center of Gravity reside at the same point, the body will have maximum possible stability in a condition called aerodynamic equilibrium. In an F1 car, the position of the Center of Pressure depends upon the magnitude of downforce generated at the various parts of the car.

- If more downforce is produced at the front wing as compared to the rear wing and diffuser, center of pressure will be in front of the Center of Gravity. This leads to oversteer at corners.
- If more downforce is produced at the rear wing as compared to the front wing, center of pressure will be behind the Center of Gravity. This leads to understeer at corners.
- Ideally, the center of pressure will be at the same position as the Center of Gravity, giving the driver maximum control at the corners.

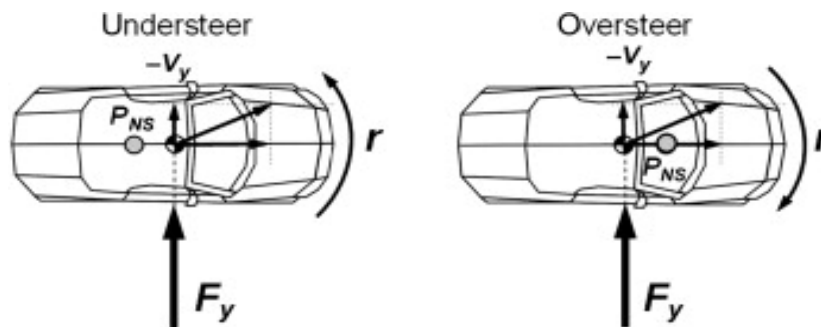

Fig 11. Position of Center of Pressure in over and understeer

In F1 cars, downforce is produced mainly at the floor, rear wing and front wing. Out of these, the floor is located in the middle and does not have much effect on the center of pressure. Therefore, the front and rear wings are the main tuning elements for altering the position of the center of pressure.

Venturi Effect

The venturi effect is a result of Bernoulli's Principle. According the venturi effect in a situation with constant mechanical energy, the velocity of a fluid passing through a constricted area will increase and its static pressure will decrease. The venturi effect is based on the Bernoulli's principle and the principle of continuity. This same principle is applied in cars to generate huge amounts of downforce with very less drag through a phenomenon called the ground effect.

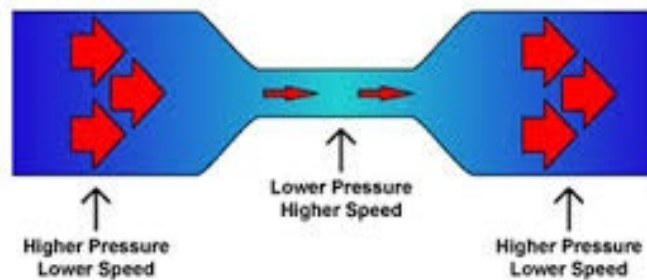

Fig 12. The Venturi Effect

AERODYNAMIC PARTS OF AN F1 CAR

The aerodynamic parts of an f1 car refer to those parts of an f1 car, which play a role in controlling the airflow in a moving F1 car. These parts are

- Front wing
- Nose cone
- Barge Boards
- Car Floor and Diffuser
- Rear Wing

Front Wing

It is the front part of the car extending through the entire length of the car, attached to the nosecone.

The front wing is designed in a shape opposite to that of the airfoil, as it is supposed to produce negative lift (downforce) this part is called the main plane. To the main plane there are many components attached to increase the functionality, thus making the design of the front wing very intricate.^[8]

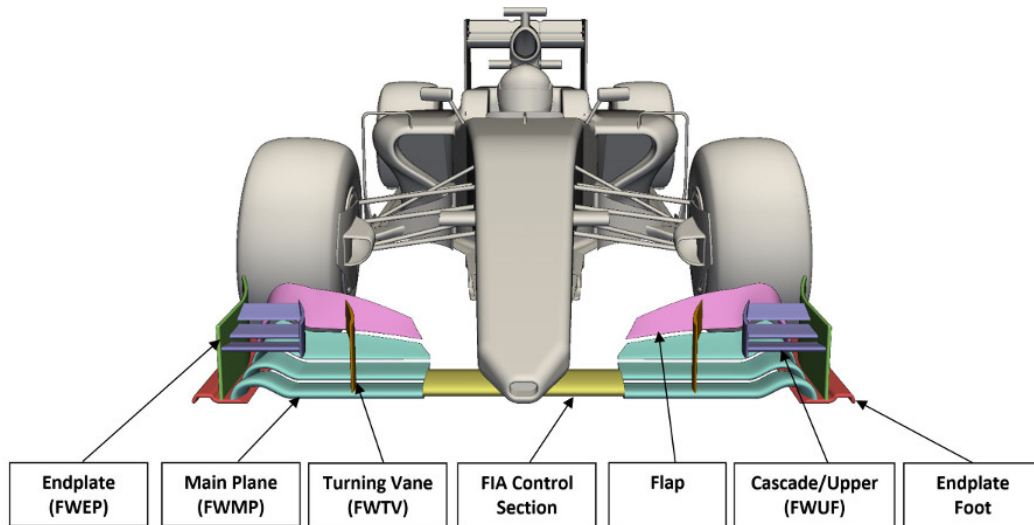

Fig 13. Parts of the Front Wing

Aerodynamically, the front wing plays one of the most important roles in the car. It has three functions.

Downforce Generation

The front wing generates downforce equivalent to twice the weight of the car. The front wing is the only downforce generating devices exposed to undisturbed air and is the first part of the car that air comes in contact with. The main plane and adjustable flap are the two main parts involved in downforce generation.



Fig 14. Front Wing Design

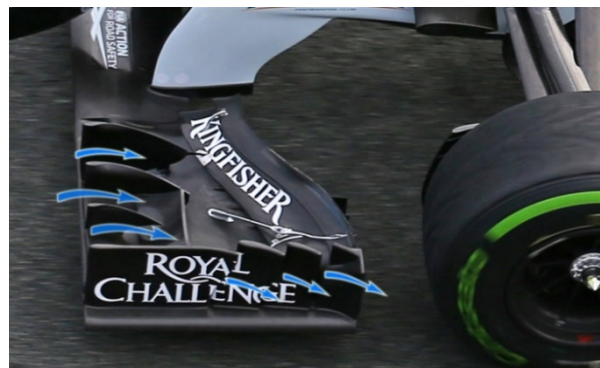

Fig 15. Airflow being directed away from the wheels outward

By adjusting the flap, the effective angle of attack of the front wing can be altered. More the angle, more the downforce. This plays an important role in tuning the center of pressure. In a track with many turns, the effective angle of attack will be made more to provide more downforce and traction for better control.

Adjusting Airflow

The front wing is located right in front of the front wheels of the car, the front wing plays an important role in ensuring that minimum air hits the wheels. The endplates direct airflow away from the tires as they are curved.

Vortex generation

The front wing comes in contact with the undisturbed air first and therefore, it sets the conditions for the rest of the car's airflow. The vortices it generates are critical.

Vortex generators themselves produce drag; however, they make up for this by playing a very important role in the keeping turbulent air away from the car body and preventing airflow separation.

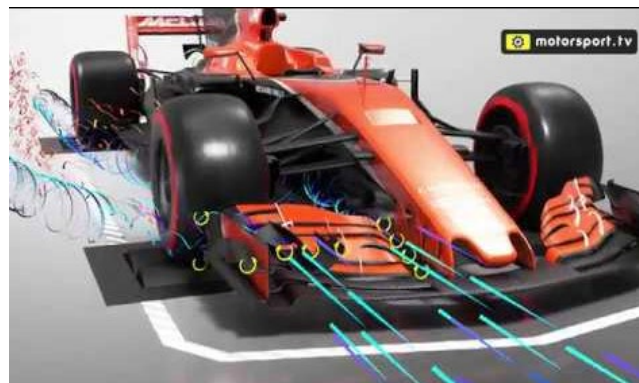

Fig 16. The 2 main vortices generated

Barge Boards

Barge boards are curved vertical planes situated longitudinally, between the front wheels and the sidepods, held away from the chassis at the front, they are aerodynamic devices also used to slow down the air entering the sidepods - and therefore both the speed and quantity of air reaching the radiators and engine bay.

Bargeboards are also used to guide turbulent air from the front wheels, away from the vital airflow underneath the car. In addition, the lower trailing edge of a bargeboard creates a vortex, which travels down the outer lower edge of the sidepod, acting as a skirt or dam, helping to seal the lower pressure area under the car. This further contributes to the ground effect.^[9]



Fig 17 & 18. Barge Board

Nose Cone

The nose cone is the part of the car which attaches the front wing to the chassis. The nose cone is required to pass a number of FDA crash tests as it supports the front wing and absorbs the impact energy in case of a head on collision. The nose cone also plays a role in the ground effect by directing part of the air hitting the front wing towards the car floor (more later).



Fig 19. A typical Nose Cone

Car Floor

The car floor refers to the area between the car and the road. Aerodynamically, the car floor is one of the most important aspects of an F1 car, it produces about 60% of the total downforce. Normally, downforce generation comes at the cost of drag due to airflow separation; however, the downforce produced by the car floor creates very less drag. This is because there is no scope for airflow separation at the bottom of the car. The car floor works on the basis of the venturi effect. When the freely flowing air enters the car floor through the nose cone, it is constricted and thus its velocity increases and pressure decreases.^[10]

Due to this, there is a pressure gradient with high pressure above, and low pressure below the car. This gradient generates huge amounts of downforce. This production of downforce at the car floor is called the ground effect. It creates a sort of suction, pulling the car towards the ground.^[11]

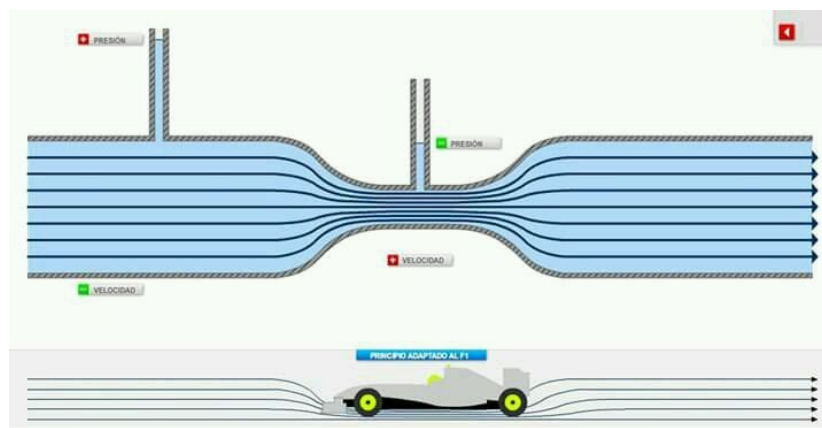

Fig 20. The car floor becomes a venturi tube

The Lotus 78 was the pioneer of the ground effect, it used side skirts which were barriers which separated the low pressure air in the car floor from the high pressure outside. The side skirts were later banned by the FIA as the ground effect was becoming too dominant. Though the side skirt was banned the ground effect has continued to be one of the basic methods of downforce generation in F1 cars.

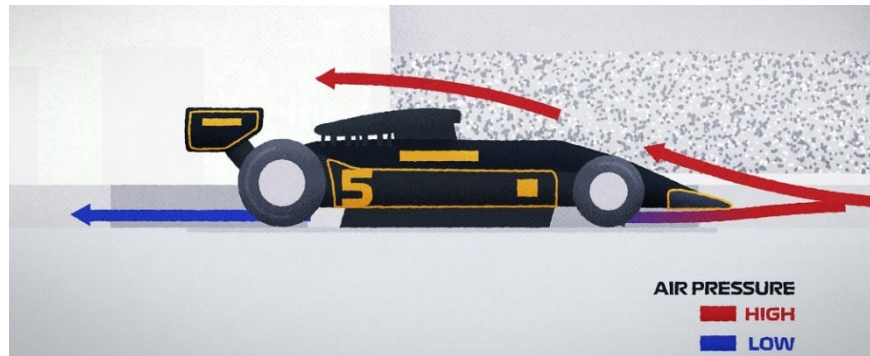

Fig 21. Pressure Differences due to The Ground Effect

Rear Wing

The rear wing according to the FIA regulations is the “Bodywork behind the rear wheel center line.” Rear wing is the last part of an F1 car, it produces about 15 to 25 % of the car’s downforce depending on the track.

The rear wing is the one part in the F1 car, which changes most with tracks, depending upon how many turns there are. The rear wing is an airfoil which is inverted as compared to a plane wing. This is because it produces downforce.

[12]

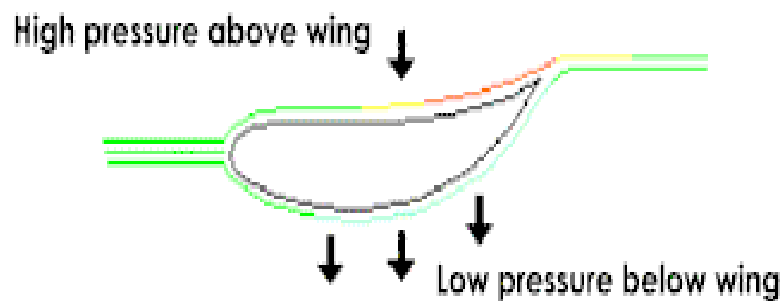

Fig 22. The reverse Airfoil

Wing Tip Vortices

Due to the airfoil shape of the rear wing, there is a pressure difference across its surfaces. Due to this gradient, vortices are generated, they are called wing tip vortices.^[13]

Unlike the vortices produced by the front wing, wing tip vortices are disadvantageous. As wing tip vortices are regions of low pressure, they produce induced drag.

The above car has much smaller vortices than what would normally be generated as it has rear wing endplates.

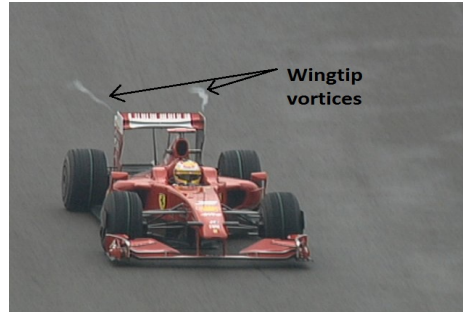

Fig 23. Actual Wing Tip Vortices

Rear Wing Endplates

In order to prevent wing tip vortices from forming, the rear wing has endplates which are vertical structures preventing the high pressure air from mixing with the low pressure.

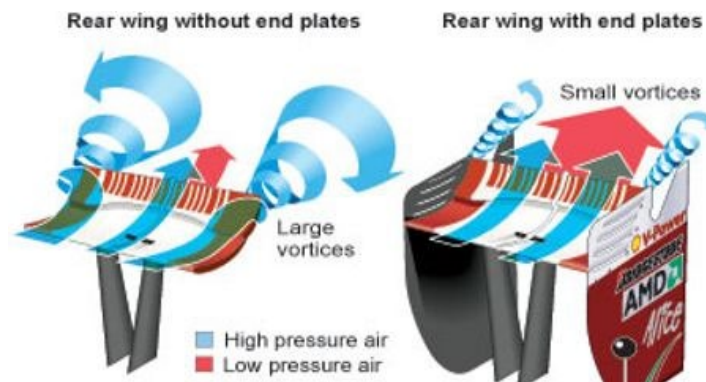

Fig 24. The utility of Endplates

Survey of People Involved in STEM

The survey will be used to understand people's opinion on the role of aerodynamics in F1 car design and its comparison with other factors in an F1 car.

Survey Objective

The objective of this survey is to explore the correlation between people in STEM, and their specific knowledge of F1 Car Aerodynamics. After this survey, we will have an idea of how well-versed people in STEM are about specific disciplines. This can also be extended to other specific fields.

Hypothesis

The results will display that while people have knowledge of general STEM, their F1 Aerodynamics knowledge, while logically sound, often fails to recognize certain intricacies of the sport.

Data Collection Methodology

The data was collected using 2 mediums-

- Amazon Mechanical Turk with Engineering as a necessary job function. This method is proven to be as reliable as other data collection methods. Amazon Mechanical Turk is a crowdsourcing website for businesses to hire remotely located "crowdworkers" to perform discrete on-demand tasks that computers are currently unable to do. It is operated under Amazon Web Services, and is owned by Amazon. We have used the survey function of Amazon Mechanical Turk to gather the data, a necessary job function under the survey is "Engineering", which ensures that only people with a background in STEM can respond to the survey.
- Face to face interviews were conducted with STEM professors and teachers at nearby institutions. These professors were chosen on recommendations of peers as well as teachers. These professors were found through college websites, and a cold mail was sent, the ones responding were interviewed for the survey.

Survey Participants and Replicability

The participants were individuals involved in the STEM Field, this includes either people who have a degree in engineering or a science related subject, and people who are currently working in engineering or scientific industries. Amazon Mechanical Turk is an international organization with no geopolitical bias, so the respondents to the survey represent a large variety of social, geographical, and economic demographics. Pre-existing literature overwhelmingly concludes that Mechanical Turk is an efficient, reliable, cost-effective tool for generating sample responses that are largely comparable to those collected via more conventional means^[14]. So, as F1 Aerodynamics is a fairly niche field this study is replicable almost everywhere. Apart from the exception of certain areas in Europe, where F1 is very popular (example – Monaco).

Survey Questions

The survey was conducted on Qualtrics.com, and consisted of 6 objective questions, and 6 subjective questions

· What do you think is most important in F1 cars?

Engine design

Car body design

Some other aspect

· Rate the importance of weight of the car in F1 car design from 1 to 100 (0 – not important 100-super important).

0 10 20 30 40 50 60 70 80 90 100

Importance

· Do you think the aerodynamic design of the car impacts the experience of driving it? Justify (20-30 words)

· What is the most important factor taken by F1 car designers?

Airflow around the car

Heat distribution around the car

Interaction between the wheels and the road

Something else

· Rate the importance of the aerodynamic design of an f1 car when considering its safety while driving (chances of crashes), from 0 to 100 (0- not important 100-super important)

0 10 20 30 40 50 60 70 80 90 100

Importance

· Order the following components in order of their aerodynamic importance in F1 Car design. (1-most important, 8- least important)

- 1 Nose Cone
- 2 Rear Wing
- 3 Barge Board
- 4 Sidepod
- 5 Car floor
- 6 Diffuser
- 7 Tyres
- 8 Front Wing

· How important do you think the car floor design is in determining aerodynamic efficiency of an F1 car (0-not important 100- super important)?

0 10 20 30 40 50 60 70 80 90 100

Importance

· Have you ever observed any aerodynamic parts in the commercial cars you have seen? If yes, please elaborate (20-30 words).

· In your opinion, what aerodynamic principles play a role in F1 Car Design (20-30 words)?

· Order the following areas in an F1 car according to their aerodynamic importance (1- most important 3-least important)

Data Filtration

The survey included objective as well as subjective questions. While the subjective questions have not been used in the analysis, they have been used to filter the data. The data of all people who have answered the subjective questions lazily has been removed from the analysis, this applied only to the data obtained using Amazon Mechanical Turk. This way we ensure that all data received is accurate. After analysis, there were little over 200 responses.

Limitations

The limitations of the data collected include.

- The accidental person who is actively involved in F1 responding to the survey.
- Misinterpretation of the question
- Not reaching all demographics due to certain limitations of Mturk, while over 200 responses were recorded, it is not necessary that a statistically significant percentage of the respondents were evenly distributed. Here, the issues with certain regions where F1 is very popular, like Monaco, come in.

Results and Analysis

For simplicity an analysis for each question has been provided underneath the question itself.

Question 1

What do you think is most important in F1 Cars?

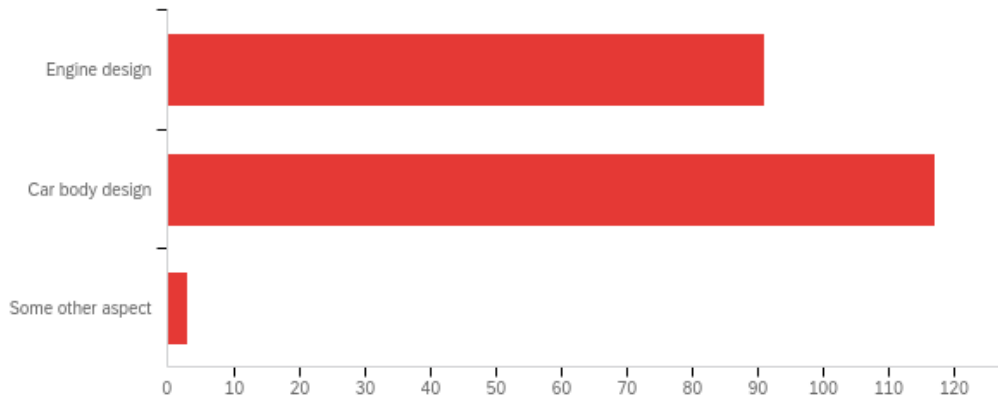

Fig 25.

As expected, most people understand the importance of car body design in F1 Car, however a statistically significant amount of people also think that the engine design is more important than car design. A reason for this may be that people do not realise that there is not much variation in all F1 Cars when it comes to engine design, and majority of the scientific effort is to make the car body design as efficient as possible

Question 2

What is the most important factor taken by F1 Car Designers?

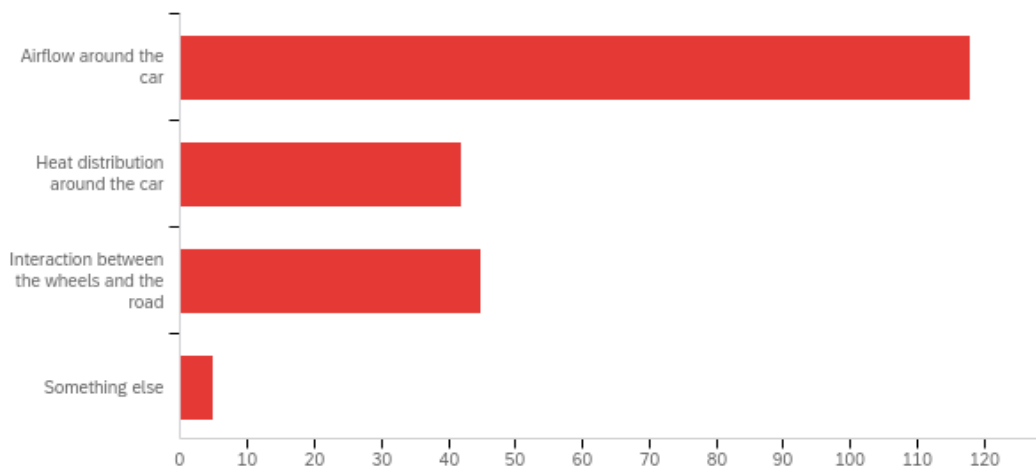

Fig 26.

Again, most respondents have answered about the airflow and aerodynamics of F1 Car design. The anomalous responses can again be attributed to how people do not know that most other metrics are standardized in F1 Cars (Pirelli is the sole tyre manufacturer, and heat distribution depends mainly on weather and engine, both of which are out of the designer's control).

Question 3

How important do you think car floor design is in determining aerodynamic efficiency of an F1 Car (0- not important, 100-very important)?

#	Field	Minimum	Maximum	Mean	Std Deviation	Variance	Count
1	Importance	0.00	100.00	71.63	20.64	425.94	210

Fig 27.

It is clear that most people understand the utility of the ground effect, considering the fact that even the left end of the standard deviation is above 50.

Question 4

How important do you think car weight is in determining aerodynamic efficiency of an F1 Car (0- not important, 100-very important)?

#	Field	Minimum	Maximum	Mean	Std Deviation	Variance	Count
1	Importance	0.00	100.00	74.28	19.72	388.73	208

Fig 28.

Again, it is clear the weight's importance is understood. We note that the weight is considered more important than car floor design. This is true and probably because people compare airplanes to F1 Cars (as aerodynamically efficient bodies) and since weight is critical in planes, they postulate that it is also critical in F1 cars.

Question 5

How important do you think aerodynamic design is in determining aerodynamic safety of an F1 Car (0- not important, 100-very important)?

#	Field	Minimum	Maximum	Mean	Std Deviation	Variance	Count
1	Importance	0.00	100.00	75.07	20.94	438.68	208

Fig 29.

People have expressed that the aerodynamic design is important, but not as important as it really is. The expected mean value was higher than 75, this anomalous result can be attributed to the fact that people do not realise the extremely high speeds at which F1 Cars operate, further they did not take into account considerations of the Center of

Pressure. Aerodynamic design doesn't play as big a role in commercial cars, which is what people are using as reference.

Question 6

Order the following areas in an F1 car according to their aerodynamic importance (1- most important 3-least important).

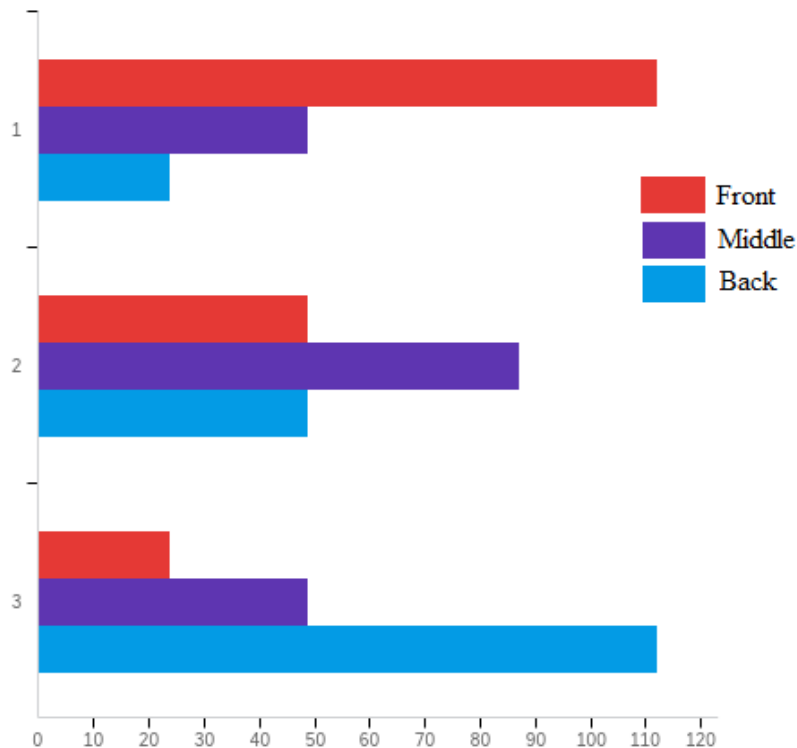

Fig 30.

It is clear that people view the front part of the car (nose cone, front wing) as the most important, middle (sidepod, bargeboards) as the second most, and back part (rear wing, diffuser) as the least. However, this is an incorrect notion. The back and front are together the 2 most important parts as they are the first and last parts to interact with air. It was probably assumed that since the back of the car meets the air last it is the least important, but in reality, it plays a huge role in creating smooth airflow behind the car, reducing induced drag.

Conclusion

We have successfully analysed all major aerodynamic principles that are used by aerodynamicists to design F1 Cars. We have also applied these aerodynamic principles to specific parts of F1 Cars and understood exactly what role each part plays in the aerodynamic efficiency of the car. We have seen how each part incorporates multiple aerodynamic concepts, for example, how the front wing generates downforce through Bernoulli's Principle and prevents turbulent airflow by directing air away from the tires, how the flaps on the rear wing adjust the angle of attack, which can alter the Center of Pressure, how the nose cone and barge boards direct airflow, and how the car floor generates huge amounts of downforce.

Further, the survey provided a unique insight into the opinions of people actually involved in STEM, the filtration methods ensured that all data was accurate and reliable. We have analysed which aspects of F1 Car Design

are well understood, such as the car floor and weight, and which are not, such as the safety and rear part of the clear. It was clear that such a survey was unique and not many people outside the automobile industry probe into the importance of all aerodynamic concepts in F1 Cars. Being involved in STEM does not guarantee that someone will be well versed with all the nuances of a specific field, though they may be familiar with some. This has been shown through various examples, where the underlying logic behind the response makes sense, but the technical details have been missed out.

Acknowledgments

I would like to thank my advisor Mr. Gwyn Harold George Day and all those people who have helped me with this project, Sobia Abdin, Pankaj Jha, and Sanjog Anand.

Reference

- [1] "[Discovering What Makes Formula One. Formula One – For Dummies](#)". *Dummies.com*. Retrieved 14 September 2009.
- [2] "[What is Lift?](#)". *NASA Glenn Research Center*. Retrieved March 4, 2021
- [3] Koch, L. (2013, April). Wings Moving Forward to Move Faster, <https://laurennkoch.wordpress.com/>
- [4] "[Inclination Effects on Lift](#)". *National Aeronautics and Space Administration*. 2018-04-05.
- [5] Brooksby, L. (2015). Fundamentals of Aerodynamics, Learn to Fly, <https://www.learntoflylv.com/aerodynamicspage1.htm>
- [6] Patricia, C. (2017). Turbulence in Nature Restarts, <https://www.fp7-restarts.eu/index.php/home/root/state-of-the-art/objectives/2012-02-15-11-58-37/72-book-video/environmental-aspects-of-the-air-transport/133-3-turbulences.html>
- [7] Preston, Ray (2006). "[Aerodynamic Center](#)". Aerodynamics Text. Selkirk College. Archived from [the original](#) on 2006-02-21. Retrieved 2006-04-01.
- [8] Petkar, R., Kolgiri, S., Ragit, S. (2014). Study of Front-Body of Formula-One Car for Aerodynamics using CFD. *International Journal of Application or Innovation in Engineering & Management (IJAIEM)*. 3. 353-359.
- [9] Smith, C. (2004). Aerodynamic Design Considerations of a Formula 1 Racing Car (980399). *Racing Chassis and Suspension Design*.
- [10] Toet, W. (2013). Aerodynamics and aerodynamic research in Formula 1. *The Aeronautical Journal* (1968), 117(1187), doi: 10.1017/1924000007739
- [11] "[The Venturi effect](#)". Wolfram Demonstrations Project. Retrieved 2009-11-03.
- [12] Ogawa, A., Mashio S., Nakamura D., Masumitsu Y., Masayuki M., Nakai Y. (2009). Aerodynamic Analysis of Formula One Vehicles. Honda R and D Technical Review
- [13] Azmi, A & Sapit, Azwan & Mohammed, Akmal Nizam & Razali, Mohd & Sadikin, A & Nordin, Normayati. (2017). Study on airflow characteristics of rear wing of F1 car. *IOP Conference Series: Materials Science and Engineering*. 243. 012030. 10.1088/1757-899X/243/1/012030.
- [14] Dupuis, M., Popovsky, B., Crossler, R. (2017) An Analysis of the Use of Amazon's Mechanical Turk for Survey Research. faculty.washington.edu/